

# Thermo PRO

Rapid ThermoPRO for low noise granulation of skeletal waste.

- **Open-Hearted design.**
- **Lower energy consumption with double-scissors cutting action.**
- **3 types of loop control** – fully integrated, external or free-standing loop control for in-line integration with the thermoforming machine.
- **Constant Cutting Circle (CCC).**
- **MCT** – mineral composite base for reduced vibrations.
- **Reversible screen** – for longer life.
- **Pre-adjustable knives** for optimal knife sharpness.



Specifications		400-60 KURTF	400-90 KURTF	400-120 KURTF
Rotor diameter	mm	350	350	350
Rotor type		3-blade, open		
Rotating knives		3	3	2x3
Fixed knives		2	2	2x2
Cutterhouse Super-Tagential	mm			
Cutterhouse Tagential	mm	620x360	920x360	1220x360
Motor (Standard)	kW	11	15	22
Motor (Optional)	kW	11 / 15 / 18,8 / 22 / 32 / 37		
<b>Dimensions</b>				
A	mm	620	920	1220
B	mm	1360	1660	1960

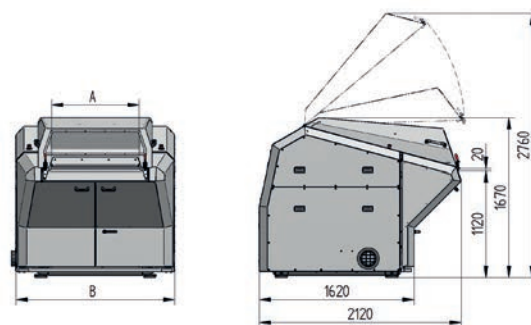

Thermo PRO