

Raptor

DUO

ONE-step solution. Fully integrated granulator into the Raptor chassis.
Based on the bespoke Rapid 400 series. Bolted modular design enables easy change of wear parts.

- Open-Hearted design.
- Lower energy consumption with double-scissors cutting action.
- Pre-adjustable knives for optimal knife sharpness.
- High quality regrind.
- Reversible screen – for longer life.
- Constant Cutting Circle (CCC).



Specifications		Shredder
Rotor diameter	mm	280
Rotor type		Claw
Rotating knives		39
Fixed knives		5
Cutterhouse dimensions	mm	1350x1010
Motor (Standard)	kW	22
Motor (Optional)	kW	15 / 18,5 / 22 / 30 / 37 / 45
		Granulator
Rotor diameter	mm	350
Rotor type		5-blade, open
Rotating knives		10 (5x2)
Fixed knives		6 (3x2)
Cutterhouse Tagential	mm	1220x360
Motor (Standard)	kW	22
Motor (Optional)	kW	15 / 22 / 30

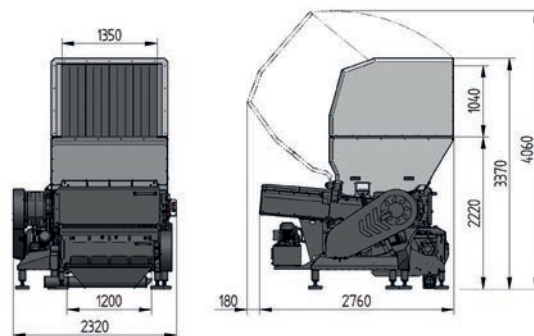

Raptor DUO